

RWE



DOWNLOAD
THE BROCHURE



WATCH THE
VIDEO

SIMEX
• patented •



WHEEL SAWS FOR DEMOLITION

category

25 - 75 TON



Exc.

models

RWE 60 | RWE 80 | RWE 90 | RWE 100

The RWE 60-80-90-100 wheel saw models are designed for heavy excavators to cover all those job sites where cuts need to be made on **horizontal or vertical surfaces and in the presence of very resistant and abrasive materials**. They enable making set-section cuts on hard and compact surfaces: asphalt, cement, rock. Ideal for demolition and underwater works.



- A** Cutting disks for 600-800-900-1000 mm working depths.
- B** Flow and pressure limiting valve ensures coupling versatility with variety of excavators.
- C** Two high-displacement, radial piston hydraulic motors, in direct drive with the drum, guarantee high torque and generate high tooth force.

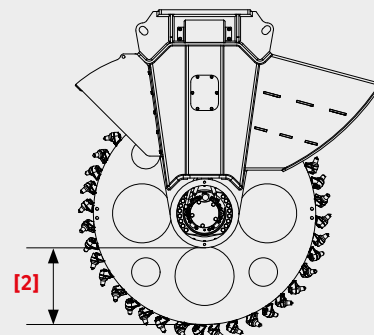
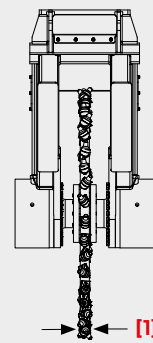

| TECHNICAL DATA | | RWE 60 | RWE 80 | RWE 90 | RWE 100 |
|---|-------|-----------------|-----------------|-----------------|-----------------|
| Recommended excavator weight (*) | ton | 24 - 45 | 50 - 75 | 50 - 75 | 50 - 75 |
| | lbs | 61000 - 99000 | 110000 - 165000 | 110000 - 165000 | 110000 - 165000 |
| Width [1] | mm | 100 - 130 - 200 | 130 - 200 | 130 - 200 | 130 - 200 |
| | inch | 4 - 5 - 8 | 5 - 8 | 5 - 8 | 5 - 8 |
| Depth [2] | mm | 600 | 800 | 900 | 1000 |
| | inch | 24 | 32 | 35 | 39 |
| Maximum applicable power | kW | 100 | 220 | 220 | 220 |
| Max. tooth force (***) | kN | 23 | 55.7 | 50.2 | 44.8 |
| | lbf | 5170 | 12520 | 11285 | 9891 |
| Hydraulic motors | no. | 2 | 2 | 2 | 2 |
| Operating weight (**) | kg | 2550 | 5000 | 5550 | 6175 |
| | lbs | 5600 | 11000 | 12200 | 12350 |
| Required oil flow | l/min | 200 - 350 | 400 - 450 | 400 - 450 | 400 - 450 |
| | gpm | 53 - 93 | 106 - 120 | 106 - 120 | 106 - 120 |
| Maximum oil pressure | bar | 350 | 350 | 350 | 350 |
| | psi | 5100 | 5100 | 5100 | 5100 |

* The installer is responsible for ensuring that the equipment meets the excavator's specifications and weight requirement. ** Without mounting bracket. *** Cutting force at 350 bar pressure. Simex does not accept responsibility or liability for the information provided. Technical modifications may vary without prior notice.